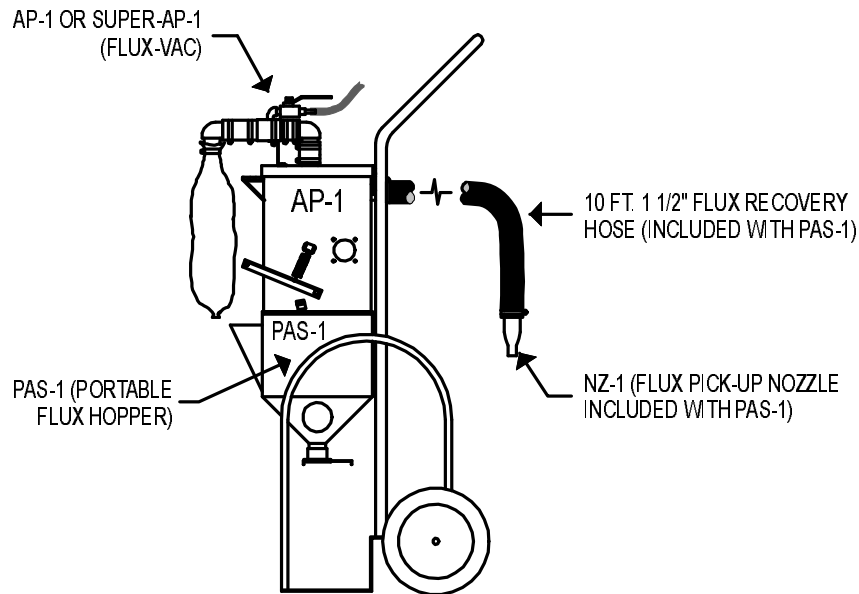

**FIG. 16:**

AP-1 OR SUPER-AP-1 FLUX-VAC MOUNTED TO PAS-1 PORTABLE FLUX HOPPER. CONVERTS AP-1 OR SUPER-AP-1 INTO A PORTABLE FLUX-VAC.



**RECOMMENDED SYSTEM ORDER LIST:**

- 1) AP-1 OR SUPER-AP-1 (FLUX-VAC)  
INCLUDED WITH FLUX-VAC AT NO EXTRA COST:  
A) 1 1/2" FLUX RECOVERY HOSE (5FT. LONG).  
B) HOPPER TO AP-1 MOUNTING BRACKETS.  
C) NZ-1 (FLUX PICK-UP NOZZLE).  
D) 2 HOPPER SIGHT WINDOWS.
- 2) OPTIONAL PAS-1 (PORTABLE FLUX HOPPER).  
INCLUDED WITH PAS-1 AT NO EXTRA COST:  
A) 1 1/2" FLUX RECOVERY HOSE (10FT. LONG)  
B) NZ-1 (FLUX PICK-UP NOZZLE).

**FIG. 17:**

AS-4 FLUX-VAC MOUNTED TO PAS-1 PORTABLE FLUX HOPPER. CONVERTS AS-4 INTO A PORTABLE FLUX-VAC.

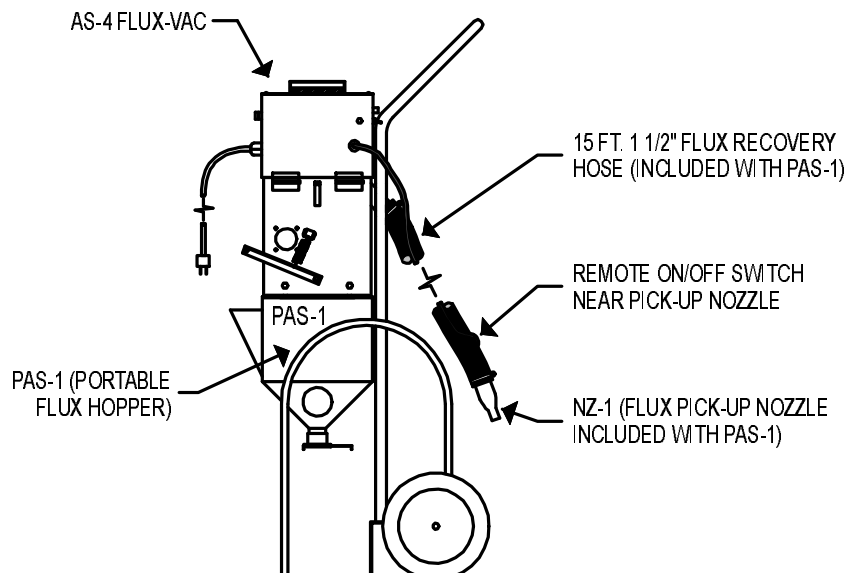

**RECOMMENDED SYSTEM ORDER LIST:**

- 1) AS-4 (FLUX-VAC)  
INCLUDED WITH AS-4 AT NO EXTRA COST:  
A) 1 1/2" FLUX RECOVERY HOSE (5FT. LONG).  
B) HOPPER TO AS-4 MOUNTING BRACKETS.  
C) NZ-1 (FLUX PICK-UP NOZZLE).  
D) 2 HOPPER SIGHT WINDOWS.
- 2) OPTIONAL PAS-1 (PORTABLE FLUX HOPPER).  
INCLUDED WITH PAS-1 AT NO EXTRA COST:  
A) 1 1/2" FLUX RECOVERY HOSE (15 FT. LONG)  
B) NZ-1 (FLUX PICK-UP NOZZLE).